

D6R Series II

Track-Type Tractor



Engine	C9	
Standard		
Gross Power	157 kW	210 hp
Flywheel Power	138 kW	185 hp
XL/XW/LGP		
Gross Power	159 kW	213 hp
Flywheel Power	141 kW	189 hp

Operating Weights		
Standard	18 325 kg	40,400 lb
XL	18 709 kg	41,252 lb
XW	19 904 kg	43,888 lb
LGP	20 451 kg	45,086 lb
Blade Capacity Range	3.18 m³ – 5.62 m³	4.16 yd³ – 7.35 yd³

D6R Series II Track-Type Tractor

The D6R Series II power, response and control deliver more production at lower cost-per-yard.

Engine

- ✓ The rugged, easy-to-service C9 engine features an electronically controlled, direct injection fuel system for improved fuel efficiency and reduced emissions. The C9 meets EPA, EU and JMOE emissions regulations. **pg. 4**

Advanced Modular Cooling System (AMOCS)

- AMOCS utilizes an exclusive two pass cooling system and increased cooling surface area to provide significantly more cooling efficiency than conventional cooling systems.
- ✓ Air-to-air aftercooler improves engine performance and reduces emissions. **pg. 5**

Drive Train

- ✓ Matched with the electronic engine control, the Caterpillar® electronic transmission control allows the power train to work more efficiently. **pg. 6**

Undercarriage

With the elevated sprocket design, the final drives are located above the work area, isolating them from ground induced impacts. The different undercarriage configurations allow you to match the machine to the application. **pg. 13**

Serviceability

Major components have a modular design for excellent serviceability and fast in-field component exchange. **pg. 14**

Total Customer Support

Your Cat® Dealer offers a wide range of services that can be set up under a customer support agreement when you purchase your equipment. The dealer will help you choose a plan that can cover everything from machine and attachment selection to replacement, helping you get the best return on your investment. **pg. 15**

Engineered for demanding work, the D6R Series II is designed to be productive in a variety of applications. It keeps material moving with the reliability and low operating costs you expect from Caterpillar machines.

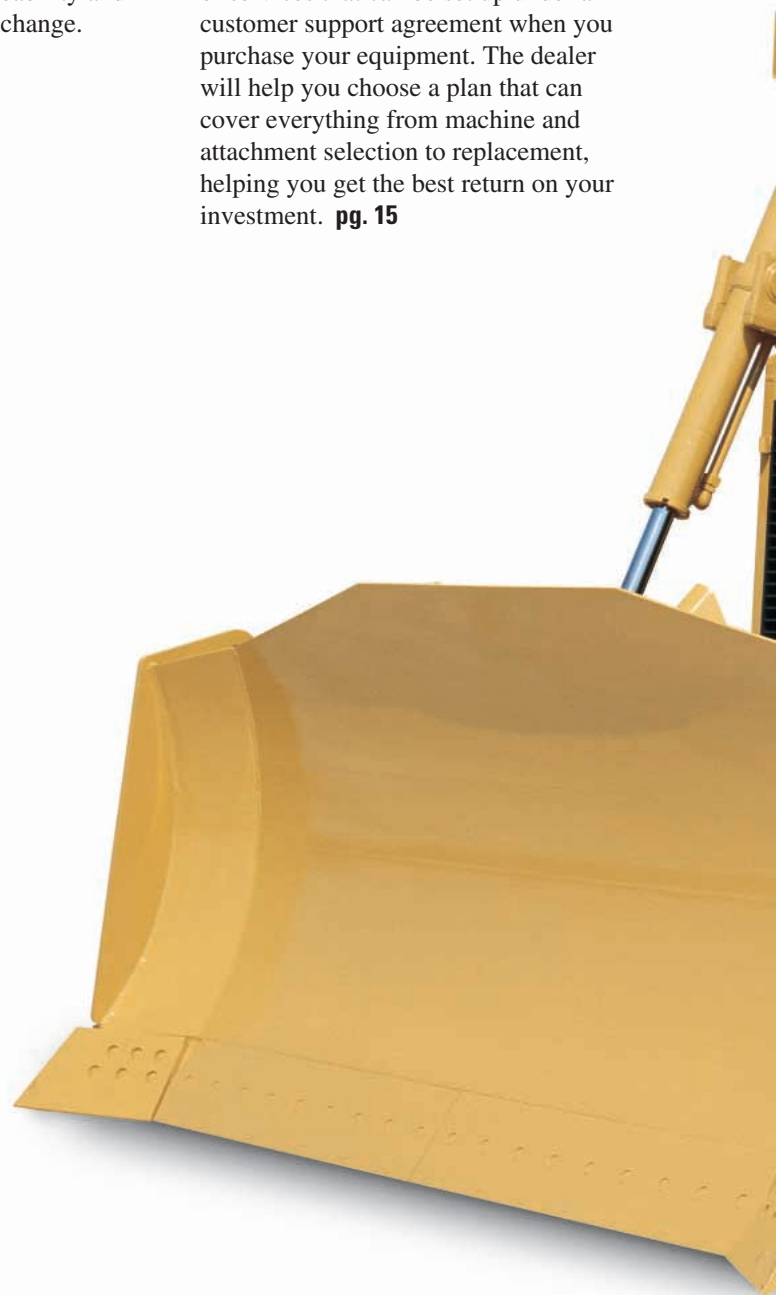

Operator's Station

- ✓ The comfortable operator's station provides excellent viewing area to the blade and rear of the machine for maximum operator productivity. Controls are low-effort and easy to reach. **pg. 8**

Work Tools

Caterpillar offers a variety of work tools to equip your D6R II with the versatility needed to accomplish the job quickly and efficiently. **pg. 10**

Structure

Mainframe is heavy, strong and durable. Strong case, steel castings and reinforced frame rails provide durable support to the undercarriage, elevated final drives and other integral frame components. **pg. 12**



✓ *New Feature*

Engine

The C9 engine, matched with the torque divider and field proven power shift transmission, provides years of dependable service.



C9 Engine. The Caterpillar C9 engine meets worldwide emissions regulations for the Environmental Protection Agency (EPA), the European Union (EU) and the Japan Ministry of Construction (JMOC).

- Wastegated turbocharger for improved response.
- Extended oil change intervals.

Cylinder Liners. Mid-supported wet cylinder liners provide excellent durability and rebuildability.

Advanced Fuel System. The C9 features an electronically controlled, hydraulically-actuated, direct injection fuel system that provides improved fuel economy and reduced emissions.



Cylinder Block. Engine durability begins with its foundation – the engine block. The serpentine design of the C9 block provides maximum strength in a reduced weight design. It is a single-piece, deep-skirted design providing a solid base for the durability you require in today's D6R II.

Cylinder Head. The C9 cylinder head is designed for maximum breathing, which helps ensure excellent fuel efficiency. This one-piece, stress-relieved, gray-iron casting has four valves per cylinder. Robust intake and exhaust valves aid airflow and provide excellent reliability and fuel efficiency.

Pistons. The two-piece articulated piston design consists of a forged-steel crown for maximum strength and a cast aluminum skirt to reduce weight. A large piston pin holds the crown, skirt and connecting rod together. The aluminum skirt runs cooler than conventional pistons, allowing a closer fit to the cylinder liner and providing longer life. The steel crown handles the higher internal pressures of today's engines.

Crankshaft. The crankshaft is a steel forging with induction-hardened journals and fillets. The wide center and end main journals and bearings are designed to maintain maximum oil film thickness for excellent lubrication and for cooling the bearings. The result is long life-to-overhaul.



Advanced Modular Cooling System (AMOCS)

AMOCS utilizes an exclusive two pass cooling system and increased cooling surface area to provide significantly more cooling efficiency than conventional systems.

Two Pass Cooling System. Using a two pass system, the AMOCS radiator provides a more efficient heat exchange. The coolant is routed from a sectioned bottom tank up the front side, over the top of the core and down the engine side of the core to the bottom tank. This flow pattern allows the coolant to pass through the radiator twice for better cooling.

Modular Design. The cooling elements are individual core modules connected to a sectioned bottom tank. There is no top tank to remove.

- Standard nine steel fins per 2.54 cm (1 in), or an optional 6 steel fins per 2.54 cm (1 in).
- Brass tube construction within each core for improved reliability.

Air-to-Air Aftercooler. The D6R II features air-to-air aftercooling. Dedicated air-to-air aftercooler circuit provides cooler inlet air temperatures, which improves performance and reduces engine emissions.

Serviceability. Modular core design permits removal of a single core without removing the entire radiator, which reduces repair costs and downtime. AMOCS eliminates the top tank, side channels and one sealing surface, making it more reliable and easier to service. It features a site gauge for quick service checks.

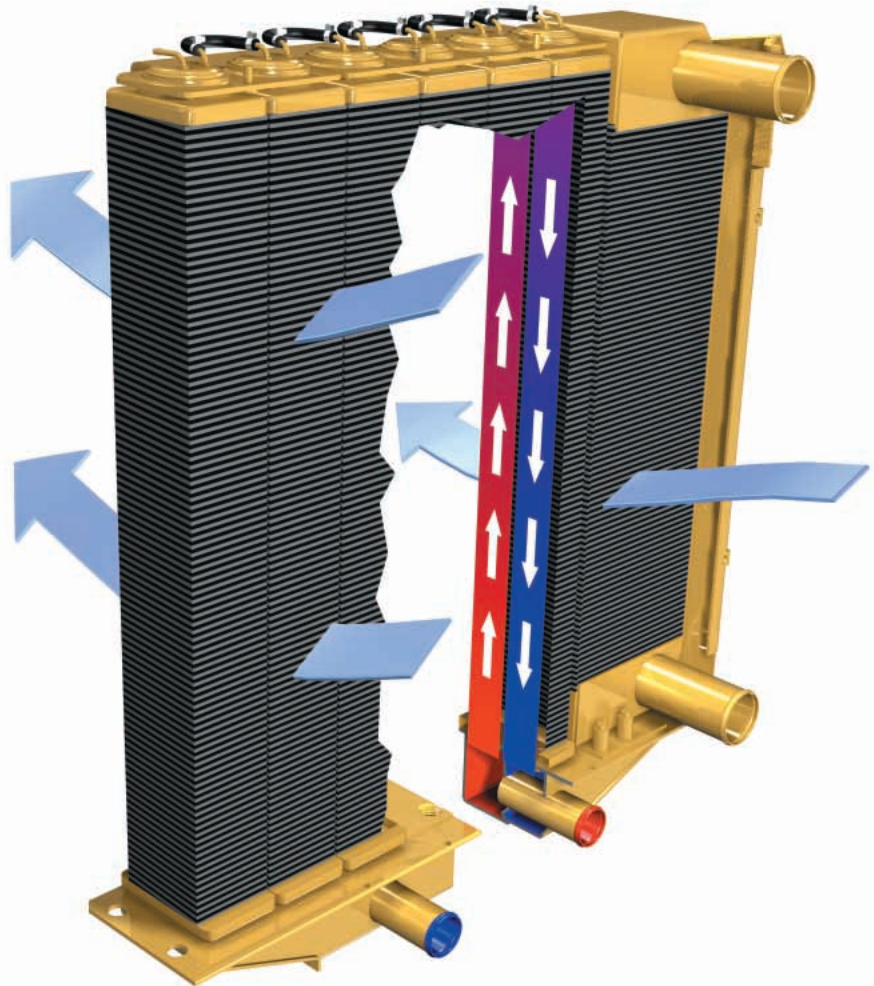

Protection From Leaks. To reduce the potential for coolant leaks, brass tubes are welded to a large, thick header, improving strength of the tube-to-header joint. In conditions where abrasive materials can be airborne, use the attachment sand blast grid to prevent core damage.

Sand Blast Grid. In an application where airborne debris is prevalent, radiator core protection is a concern. To extend radiator life in harsh applications, a sand blast grid is available as an option to deflect the damaging debris the engine fan propels at the radiator.

Drive Train

Get maximum power to the ground with the efficiency and reliability you expect from Caterpillar machines.

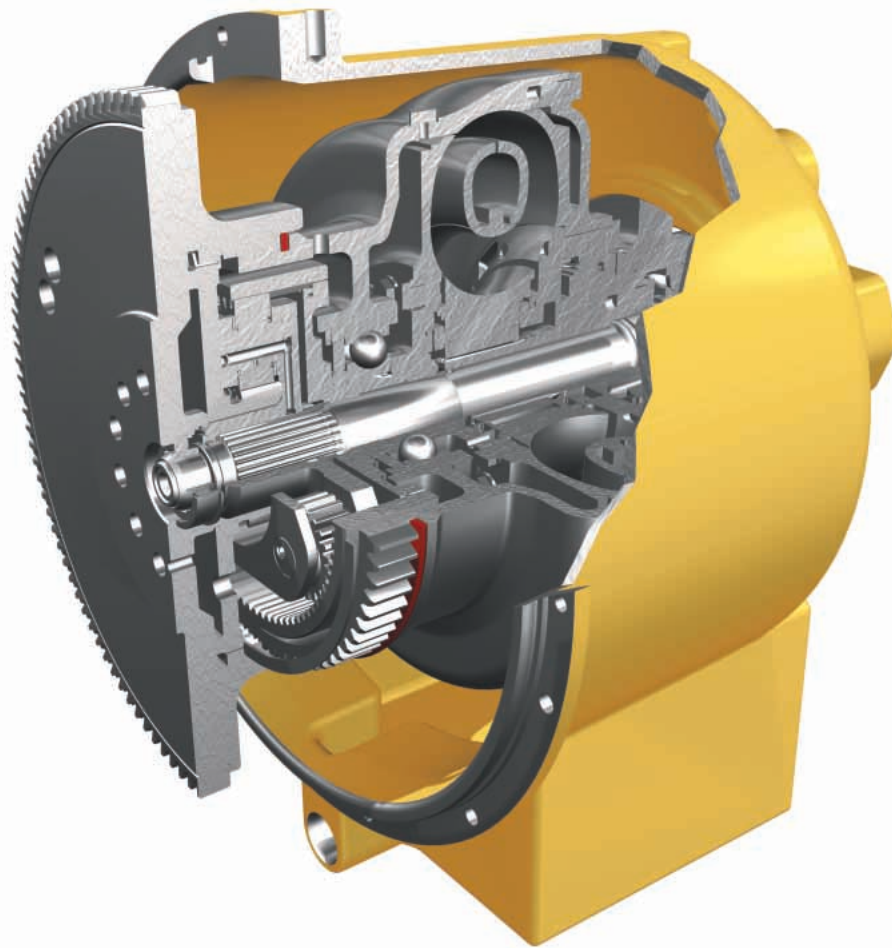

Torque Divider. A single stage torque converter sends 70% of engine torque through a converter and 30% through a direct drive shaft for greater driveline efficiency and higher torque multiplication to get heavy loads moving. The torque divider provides improved efficiency and broader range of performance in second gear applications.

Key Benefits of a Torque Divider.

The D6R II torque divider provides:

- High reliability.
- Low dynamic torque.
- Optimum combination of operator efficiency and driveline reliability.
- Components are designed to absorb full engine power.

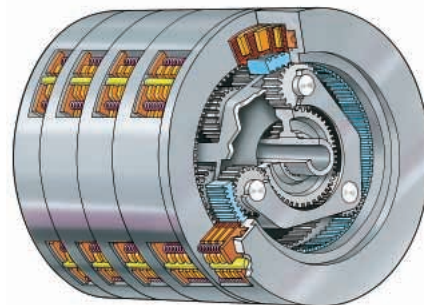

Transmission. The D6R II planetary power shift transmission features three speeds forward and three speeds reverse and utilizes large diameter, high-capacity, oil-cooled clutches. To maximize the life of the transmission, the planetary design distributes loads and stresses over multiple gears.

- Controlled throttle shifting regulates engine speed during high energy directional shifts for smoother, more comfortable operation and longer component life.
- Electronic clutch pressure control permits fast speed and direction changes.
- Modular transmission and bevel gear slide into rear case for servicing ease, even with ripper installed.
- Oil-to-water cooler for maximum cooling capacity.
- Forced oil flow lubricates and cools clutch packs to provide maximum clutch life.

Operating Efficiency and Driveline Reliability. The D6R II torque divider attains the best combination of operating efficiency and driveline reliability. It reduces dozing shock loads to the transmission and final drives by acting as a hydrodynamic component between the engine and transmission.

Finger Tip Control. The D6R II with Finger Tip Control features low effort finger tip levers for steering and touch shift buttons for upshift and downshift. The steering clutches and brakes are fade resistant and adjustment free. Multi-disk, oil-cooled steering clutches are hydraulically applied and electronically controlled. Brakes are applied by springs and hydraulically released for safe, reliable braking performance.

Differential Steering. A D6R II equipped with differential steering maintains power to both tracks while turning. The tractor turns when one track speeds up and the other slows down an equal amount. The operator can steer and control the transmission simultaneously which can reduce cycle times in some applications. The differential steering tiller bar has touch shift buttons for upshifts and downshifts. The tiller bar itself is easily rotated forward or reverse to change the respective tractor direction. The tiller bar is moved forward to steer the tractor to the left and pulled back to go right. Low tiller bar efforts assure operator comfort during long shifts. Large blade loads can be maneuvered around buildings, bridge abutments, trees, or other obstacles. Steering modulation is also optimized for precise control in these applications. Greater load capacity, power and speed control are possible in soft underfoot conditions and on steep slopes because both tracks are powered during turns.

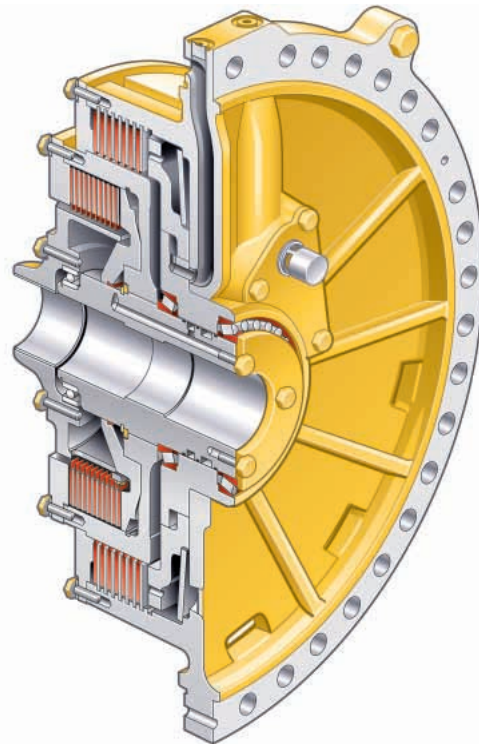

Elevated Final Drive. Isolates final drives from ground and work tool induced impact loads for extended power train life.

Thick, Large Diameter Plates and Clutch Disks. Provides higher torque capacity and increased service life.

Auto-Shift/Auto-Kickdown. Auto-shift allows the operator to pre-select a forward and reverse gear for easy, efficient directional changes. Auto-shift settings include first forward to second reverse, second forward to second reverse and second forward to first reverse. Auto-kickdown allows the transmission to automatically downshift when significant load increases are detected.

Load Compensating Shifting. Automatically adjusts the clutch engagement timing according to load factor, resulting in improved tractor performance and operator comfort during speed changes. Load compensating shifting reduces the amount of energy dissipated through the clutches to help extend transmission component life.

Operator's Station

The D6R Series II operator station is designed for comfort and ease of operation.



Cab. Isolation-mounted, pressurized cab reduces noise and vibration for operator comfort.

Clear Working View. Operator has an excellent view to the blade and rear of the machine for maximum operator productivity. The tapered hood gives the operator a clear line of sight to the front work area. The low rear window lets the operator see the ripper tip. The large single-pane door windows allow the operator to see both ends of the blade.

Interior Amenities. The D6R II operator's station interior storage and amenities include:

- Storage area behind seat for first aid kit.
- Lunchbox tie-downs.
- Cup holder and ashtray.
- Standard 24 to 12-volt converter.
- Two 12-volt plug-in receptacles behind seat.
- Perimeter-mounted headliner with integral pre-wired radio mount, speakers and antenna.
- Steep slope foot pads.
- Storage compartment for personal items.
- Adjustable armrests.
- Padded consoles for side slope operations.
- Sliding windows.

Power Converter. D6R II features a 10-amp, 12-volt power converter for the easy use of:

- FM, AM or CB radios.
- Communication radios.
- Wireless phones.
- Laptop computers.

Dash. An informed operator is a productive operator. With a newly designed instrument panel, the operator will be kept informed of machine system information. Easy to read analog gauges and a warning lamp keeps the operator aware of any action that is needed. New foot pads adjacent to the dash help the operator stay comfortable and confident during slope applications.

Caterpillar Monitoring System.

Provides the operator instant feedback on the machine conditions and records performance data to help diagnose problems. Caterpillar Monitoring System includes the following gauges and readouts:

- Fuel level gauge.
- Hydraulic oil temperature gauge.
- Engine coolant temperature gauge.
- Power train oil temperature gauge.
- Engine oil pressure indicator.
- Engine speed digital readout.
- Transmission gear indicator.

Electronic Steering and Transmission Control. The D6R II offers standard Finger Tip Control (FTC) or optional differential steering. Both steering methods deliver the maneuverability and control operators need to match to operating conditions. Touch shift buttons on the steering control shifts the electronically controlled powershift transmission. Both steering systems allow simultaneous, one-hand steering and transmission control.



Work Tool Controls. The D6R II features ergonomically designed blade and ripper controls with low effort pilot operated hydraulics for added operator comfort, easy operation and precise work tool control. When equipped with a PAT blade, the blade control allows simultaneous six way control of the blade with a thumb rocker control to adjust blade angle.

Work Tool Lock-out. The lock-out valve prevents inadvertent operation of the hydraulic work tool attachments.

Throttle Rocker Switch. A rocker switch control activates high or low idle with a touch of a finger. A decelerator pedal gives the operator full control of engine speed when the rocker switch is in the high idle position.

Caterpillar Comfort Series Seat. The D6R II features the new Cat Comfort Series Seat for increased operator comfort and reduced operator fatigue. The seat is fully adjustable and designed for comfort and support. The seat and back cushions are thicker and designed to reduce pressure on the lower back and thighs while allowing unrestricted arm and leg movement.

Work Tools

Cat D6R Series II work tools are designed to provide flexibility to match the machine to the job.



Caterpillar Blades. With superior moldboard and cell structure design, Cat bulldozer blades load easily and are durable. Cat high-tensile strength blades resist torsional bending and deflection in tough applications.

Pilot Operated Hydraulics. The D6R II features work tools that are controlled by pilot hydraulics that reduces lever efforts and provides unmatched modulation and control.

Power Angle Tilt Blade. A Power Angle Tilt (PAT) Blade on the D6R II allows the operator to hydraulically adjust the blade lift, angle and tilt simultaneously using the ergonomically designed blade control handle. The versatility of the PAT blade gives the D6R II the ability to take on a variety of applications, such as finish grading, spreading material, side casting, V-ditching and backfilling. The PAT blade is available on the differential steer XL, XW and LGP configurations and requires a rear work tool attachment. Operation in large rock or stump applications is not recommended.

Semi-Universal Blade. Built for tough applications where penetration is important, the SU blade is aggressive in penetrating and loading material. The blade wings are designed for superior load retention. It can be configured with a push plate for pushloading scrapers.

Straight Blade. The S-blade provides good versatility. Since it has less blade capacity it can handle heavier materials than a larger blade. The front of the S-blade is closer to the front of the tractor making it easier to maneuver on small and congested job sites. The S-blade can be configured with a push plate for pushloading scrapers.

Angle Blade. The angle blade is mounted to a C-frame, using a pinned connection which permits blade angling and tilting, left or right.

Cutting Edges. High-tensile strength Cat DH-2 steel cutting edges resist torsional bending and distortion in tough applications. End bits are DH-3 to provide maximum service life in tough materials.

Load Sensing Hydraulics. Field-proven load-sensing pilot controlled hydraulics respond to operating requirements by automatically and continually adjusting hydraulic power to maximize work tool efficiency.



Multi-Shank Ripper. The multi-shank parallelogram ripper lets you choose one, two or three shanks depending on job conditions. Curved or straight ripper shanks are available.

Drawbar. The D6R II can be equipped with a drawbar for pulling work tools such as:

- Disks.
- Compactors.
- Chopper wheels.
- Retrieving other equipment.

Winch.

- Single lever control actuates both clutch and brake functions to improve operator efficiency.
- Input clutches on PTO shaft reduce engine horsepower losses, provide fuel efficiency and economy.
- Clutch engagement and brake release are automatically synchronized for smooth operation.
- Winch components can be serviced with winch mounted on tractor.

Forestry Sweeps. In applications where tree limbs can damage a machine, optional forestry sweeps are available to protect your investment. Sweeps help shield intake air cleaners, exhaust stack, cab windows and lights from damage.



Rear Counterweight. Rear counterweights may be needed to optimize balance for backing up steep slopes or increasing performance in heavy dozing applications. Recommended if other rear attachment is not specified.

Structure

Engineered and built to give solid support in the most demanding work.



Frame and Castings. The D6R II frame is built to absorb high impact shock loads and twisting forces. Castings are added to provide added strength to the main case.

L-Shaped Push Arms. L-shaped push arms bring the blade closer to the machine than diagonal brace design for excellent maneuverability, machine balance and blade penetration. The L-shaped push arm design provides solid lateral stability and better cylinder positions for constant pryout independent of blade height.

Pivot Shaft. The pivot shaft is bolted to the mainframe and connects to the roller frames for independent oscillation. The strong pivot shaft distributes impact loads throughout the case, reducing bending stresses on the case. This design eliminates alignment problems and the need for diagonal braces on the roller frames. Caterpillar Track-Type Tractors set the industry standard for mainframe durability.



Equalizer Bar. The pinned equalizer bar gives the roller frames the ability to oscillate up or down to better match ground contours while providing maximum traction and operator comfort. Equalizer bar with optional oil filled end pin joints and limited slip seals offer longer life in severe applications and reduced repair costs.

Undercarriage

The Caterpillar elevated sprocket undercarriage arrangements allow optimized balance for the best possible performance in each application.

Undercarriage Arrangements.

Standard arrangement

- Performs well in many applications with firm to soft underfoot conditions.

XL arrangement

- More track to the front optimizes tractor balance for superior traction, blade control and stability for finish grading. Longer roller frame also improves flotation in soft underfoot conditions.

XW arrangement

- Designed to be more productive in rainy, wet or muddy conditions. Wider track gauge and shoes broadens the application range and extends the working season.

LGP arrangement

- Specially designed to work in swampy and spongy conditions. Wide track shoes, long track frames and a wider gauge increases track contact area and reduces ground pressure for improved stability and excellent flotation in swampy conditions.

Roller Frames. Roller frames are tubular, to resist bending and twisting, with added reinforcement where operating loads are the highest.

- Roller frames attach to the tractor by a pivot shaft and pinned equalizer bar.
- Large pivot shaft bushings operate in an oil reservoir.
- The recoil system is sealed and lubricated.

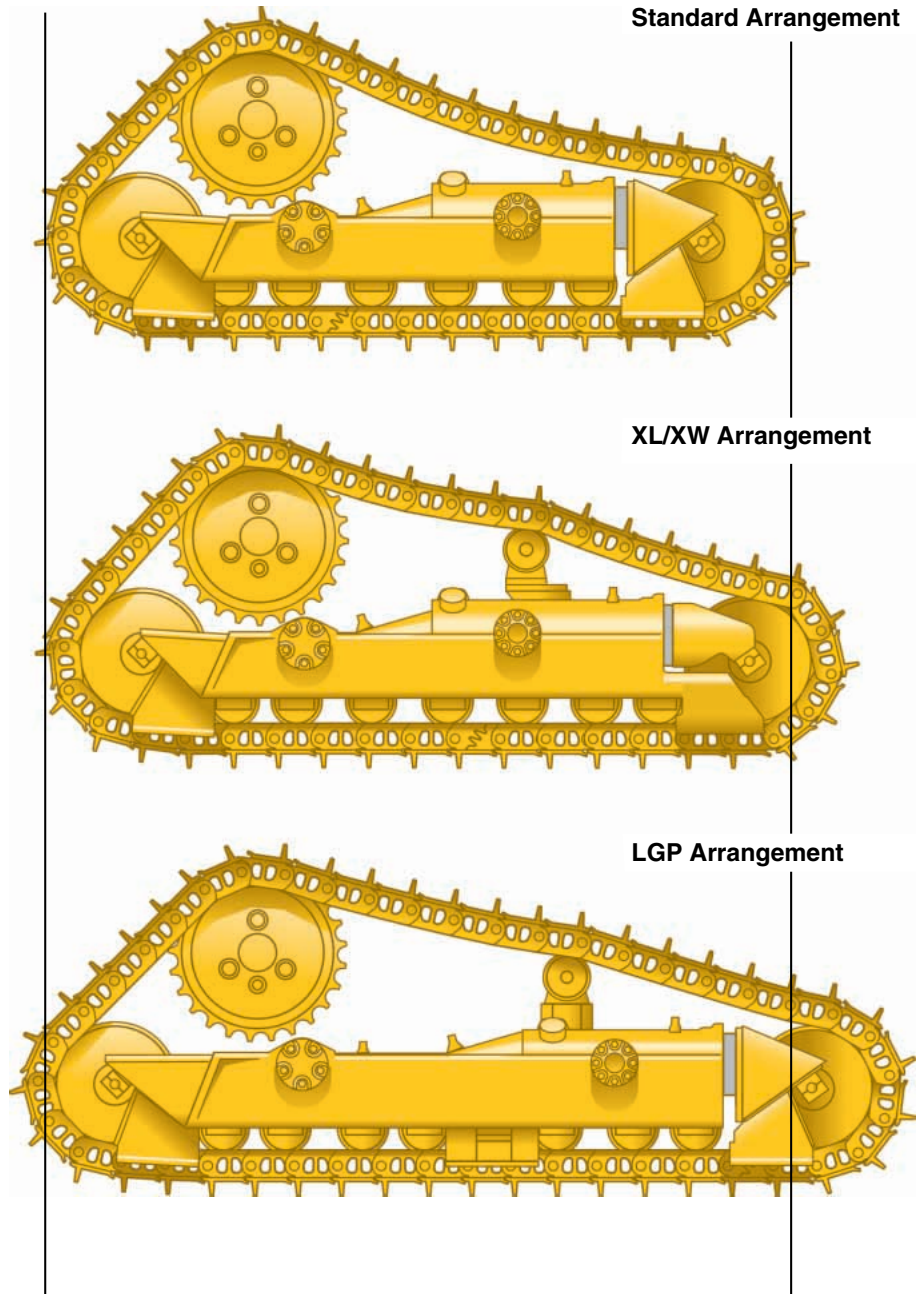

Serviceability

Simplified service means more productive uptime.



Product Link. The optional Product Link System is a factory installed or easily retrofitted wireless system that simplifies equipment fleet tracking. Using satellite technology, the Internet and your dealer's storefront website, the system automatically reports key machine parameters such as location, hour meter, active and logged service codes and forwards them to the customer through the dealer's storefront website.

Caterpillar Monitoring System.

The D6R II features a more flexible monitoring system that is easily upgraded by flashing software rather than replacing the module. As technology changes and new electronics and software become available, this upgraded monitoring system will allow the machine to be easily updated and take advantage of improvements. The Caterpillar Monitoring System is designed to:

- Allow easy upgrades.
- Reduce the parts cost.
- Reduce downtime.
- Match software to unique application needs.

Diagnostic Connector. Diagnostic connector allows Caterpillar dealers to quickly troubleshoot the D6R II or access stored data with the use of Electronic Technician (ET) or ECAP.

Pressure Test Points. Pressure test points for power train and hydraulic systems are provided.

Ecology Drains. Ecology drains provide an environmentally safer method to drain fluids. They are included on the radiator, hydraulic tank and major power train components.

Cooling System. AMOCS individual cooling elements allow radiator servicing without major component removal, saving considerable time and cost.

Built-in Serviceability. Less service time means more working time. Major components are made as modules and most can be removed without disturbing or removing others.

Total Customer Support

Unmatched in the industry!

Services. Your Cat Dealer offers a wide range of services that can be set up under a customer support agreement when you purchase your equipment. The dealer will help you choose a plan that can cover everything from machine and attachment selection to replacement, to help you get the best return on your investment.

Product Support. You will find nearly all D6R II parts at our dealer parts counter. Cat Dealers utilize a worldwide computer network to find in-stock parts to minimize machine down time. Save money with remanufactured parts. You receive the same warranty and reliability as new products at cost savings of 40 to 70 percent.

Service Capability. Whether in the dealer's fully equipped shop or in the field, you will get trained service technicians using the latest technology and tools.

Selection. Make detailed comparisons of the machines you are considering before you buy. How long do components last? What is the cost of preventive maintenance? What is the true cost of lost production? Your Cat Dealer can give you answers to these questions.

Purchase. Consider the financing options available as well as day-to-day operating costs. This is also the time to look at dealer services that can be included in the cost of the machine to yield lower equipment owning and operating costs over the long run.



Operation. Improving operating techniques can boost your profits. Your Cat Dealer has training videotapes, literature and other ideas to help you increase productivity.

Replacement. Repair, rebuild or replace? Your Cat Dealer can help evaluate the cost involved so you can make the right choice.

Maintenance. More and more equipment buyers are planning for effective maintenance before buying equipment. Choose from your dealer's wide range of maintenance services at the time you purchase your machine. Repair option programs guarantee the cost of repairs up front. Diagnostic programs such as Scheduled Oil Sampling and Technical Analysis help avoid unscheduled repairs.

Engine – Standard

Engine Model	C9	
Gross Power	157 kW	210 hp
Flywheel Power	138 kW	185 hp
Net Power – Caterpillar	138 kW	185 hp
Net Power – ISO 9249	138 kW	185 hp
Net Power – EU 80/1269	138 kW	185 hp
Net Power – SAE J1349	136 kW	183 hp
Net Power – DIN 7002	192 PS	
Bore	112 mm	4.4 in
Stroke	149 mm	5.9 in
Displacement	8.8 L	537 in ³

Engine – XL/XW/LGP

Engine Model	C9	
Gross Power	159 kW	213 hp
Flywheel Power	141 kW	189 hp
Net Power – Caterpillar	141 kW	189 hp
Net Power – ISO 9249	141 kW	189 hp
Net Power – EU 80/1269	141 kW	189 hp
Net Power – SAE J1349	139 kW	187 hp
Net Power – DIN 7002	196 PS	
Bore	112 mm	4.4 in
Stroke	149 mm	5.9 in
Displacement	8.8 L	537 in ³

- Engine Ratings at 2000 RPM.
- Net power advertised is the power available at the flywheel when the engine is equipped with fan, air cleaner, muffler and alternator.
- No derating required up to 2286 m (7500 ft) altitude, beyond 2286 m (7500 ft) automatic derating occurs.

Transmission

1 Forward	3.8 kph	2.4 mph
2 Forward	6.6 kph	4.1 mph
3 Forward	11.5 kph	7.1 mph
1 Reverse	4.8 kph	3.0 mph
2 Reverse	8.4 kph	5.2 mph
3 Reverse	14.6 kph	9.1 mph

Weights

Operating Weight – STD	18 322 kg	40,400 lb
Shipping Weight – STD	14 706 kg	32,426 lb
Operating Weight – XL	18 709 kg	41,252 lb
Shipping Weight – XL	15 092 kg	33,278 lb
Operating Weight – XW	19 904 kg	43,888 lb
Shipping Weight – XW	16 043 kg	35,374 lb
Operating Weight – LGP	20 447 kg	45,086 lb
Shipping Weight – LGP	17 114 kg	37,736 lb

- Shipping Weight
Includes lubricants, coolant, ROPS canopy, hydraulic controls, standard track and 10% fuel.
- Operating Weight
Includes lubricants, coolant, full fuel tank, SU blade with tilt cylinder, standard track, ROPS canopy, hydraulic controls, drawbar and operator.

Undercarriage – Standard

Shoe Type	Moderate Service	
Pitch	203 mm	8 in
Number Shoes/Side	39	
Grouser Height	65 mm	2.6 in
Track Rollers/Side	6	
Width of Shoe	560 mm	22 in
Track on Ground	2610 mm	103 in
Track Gauge	1880 mm	74 in
Ground Contact Area	2.92 m ²	4,532 in ²
Ground Pressure	0.63 kPa	8.9 psi
Ground Clearance	376 mm	14.8 in

Service Refill Capacities

Fuel Tank	382.3 L	101.0 gal
Cooling System	76.8 L	20.3 gal
Engine Crankcase	28.0 L	7.4 gal
Power Train	145.7 L	38.5 gal
Final Drives (each)	13.6 L	3.6 gal
Roller Frames (each)	24.6 L	6.5 gal
Hydraulic Tank	47.3 L	12.5 gal
Pivot Shaft Compartment	1.9 L	0.5 gal

Hydraulic Controls – Pump

Pump Capacity at	6900 kPa	1,001 psi
Pump RPM at Rated Engine Speed	2125 RPM	
Pump Output (Clutch Brake)	212 L/min	56 gal/min
Pump Output (Differential Steering)	217 L/min	57.3 gal/min
Lift Cylinder Flow	190 L/min	50.2 gal/min
Tilt Cylinder Flow	80 L/min	21.1 gal/min
Ripper Cylinder Flow	160 L/min	42.3 gal/min

Hydraulic Controls – Main Relief Valve Settings

Clutch Brake Models	19 300 kPa	2,799 psi
Differential Steering Models	42 000 kPa	6,092 psi

Hydraulic Controls – Maximum Operating Pressure

Bulldozer	19 300 kPa	2,799 psi
Bulldozer Tilt	19 300 kPa	2,799 psi
Tilt Cylinder	19 300 kPa	2,799 psi
Ripper (Lift)	19 300 kPa	2,799 psi
Steering	38 000 kPa	5,511 psi

Blades

Blade Type		
SU Blade Capacity	5.61 m ³	7.34 yd ³
SU Blade Width	3260 mm	10.7 ft
XL SU Blade Capacity	5.61 m ³	7.34 yd ³
XL SU Blade Width	3260 mm	10.7 ft
XW SU Blade Capacity	5.62 m ³	7.35 yd ³
XW SU Blade Width	3556 mm	11.67 ft
S Blade Capacity	3.89 m ³	5.09 yd ³
S Blade Width	3360 mm	11.02 ft
LGP S Blade Capacity	3.70 m ³	4.84 yd ³
LGP S Blade Width	3990 mm	13.09 ft
A Blade Capacity	3.18 m ³	4.16 yd ³
A Blade Width	4166 mm	13.67 ft
XL A Blade Capacity	3.93 m ³	5.14 yd ³
XL A Blade Width	4165 mm	13.66 ft
XW A Blade Capacity	4.30 m ³	5.62 yd ³
XW A Blade Width	4200 mm	13.78 ft
XL PAT Blade Capacity	4.84 m ³	6.33 yd ³
XL PAT Blade Width	3620 mm	11.88 ft
XW PAT Blade Capacity	5.08 m ³	6.65 yd ³
XW PAT Blade Width	3794 mm	12.45 ft
LGP PAT Blade Capacity	4.21 m ³	5.50 yd ³
LGP PAT Blade Width	4173 mm	13.69 ft

Multi-Shank Ripper

Type	Fixed Parallelogram	
Beam width	2202 mm	87 in
Beam cross section	216 x 254 mm	8.5 x 10.0 in
Maximum penetration	500 mm	19.7 in
Maximum clearance raised (shank tip)	511 mm	20.1 in
Number of pockets	3	
Maximum penetration force	6603 kg	14,557 lb
Maximum pryout force	9134 kg	20,137 lb
Weight – with one shank	1634 kg	3,603 lb
Weight – each additional shank	74 kg	163 lb

Winch Specifications

Winch Model	PA 56	
Weight	1179 kg	2,600 lb
Winch and Bracket Length	1210 mm	47.6 in
Winch Case Length	1210 mm	47.6 in
Winch Case Width	975 mm	38.4 in
Increased Tractor Length – STD	517 mm	20.4 in
Increased Tractor Length – XL	517 mm	20.4 in
Increased Tractor Length – XW	517 mm	20.4 in
Increased Tractor Length – LGP	397 mm	15.6 in
Flange Diameter	504 mm	19.8 in
Drum Width	330 mm	13.0 in
Drum Diameter	254 mm	10.0 in
Drum Capacity – 22 mm (.88 in)	88 m	290 ft
Drum Capacity – 25 mm (1.0 in)	67 m	220 ft
Drum Capacity – 29 mm (1.13 in)	67 m	220 ft
Ferrule Size (O.D. x Length)	54 x 67 mm	2.10 x 2.63 in
Oil Capacity	67 L	17.7 gal

Standards

ROPS/FOPS

- ROPS (Rollover Protective Structure) offered by Caterpillar for the machine meets ROPS criteria SAE J395, SAE 1040 MAY94 and ISO 3471-1994.
- FOPS (Falling Object Protective Structure) meets ISO 3449-1992 Level II.

Cab

- The operator sound exposure Leq (equivalent sound pressure level) measured according to the work cycle procedures specified in ANSI/SAE J1166 OCT 98 is 83 dB(A), for cab offered by Caterpillar, when properly installed and maintained and tested with the doors and windows closed.
- Hearing protection may be needed when operating with an open operator station and cab (when not properly maintained or doors/windows open) for extended periods or in noisy environment.
- The exterior sound pressure level for the standard machine measured at a distance of 15 meters according to the test procedures specified in SAE J88 APR 95, mid-gear-moving operation, is 86 dB(A).

Brakes

- Brakes meet the standard SAE J/ISO 10265 MARCH99.

D6R II Drawbar Pull Curves

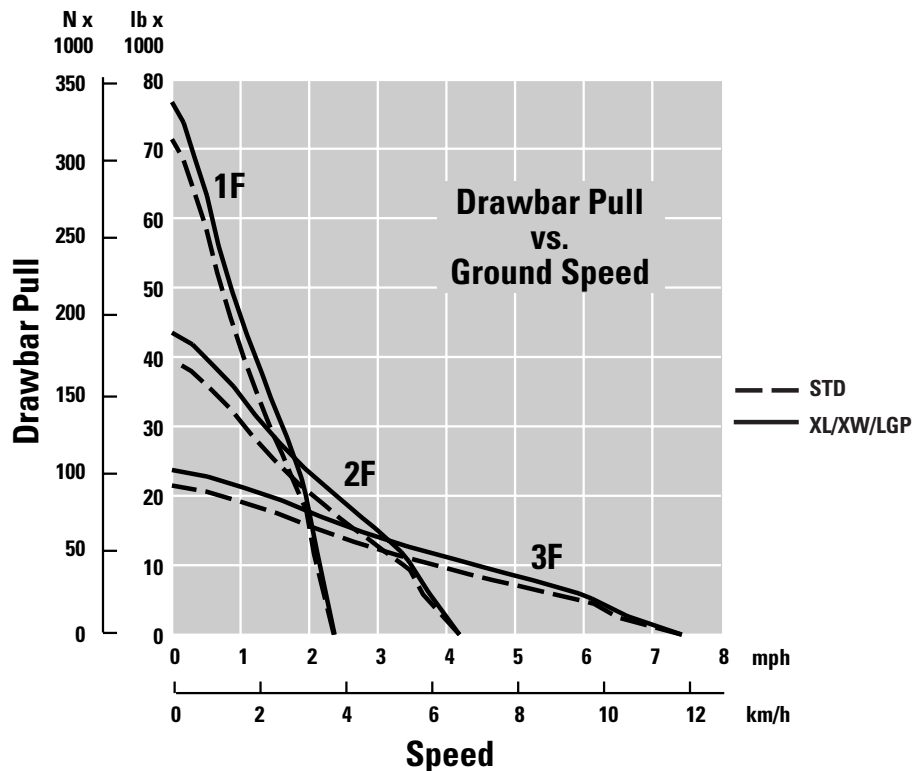

Weight (approximate)

Shipping

Includes lubricants, coolant, ROPS canopy, hydraulic controls, standard track and 10% fuel.

	STD		XL		XW		LGP	
Finger Tip Control	14 706 kg	32,426 lb	15 092 kg	33,278 lb			17 114 kg	37,736 lb
Differential Steering	15 006 kg	33,087 lb	15 392 kg	33,939 lb	16 043 kg	35,374 lb	17 414 kg	38,398 lb

Operating

Includes lubricants, coolant, hydraulic controls, full fuel tank, SU blade with tilt cylinder, standard track and operator.

	STD		XL		XW		LGP – S Blade	
Finger Tip Control	18 322 kg	40,400 lb	18 709 kg	41,252 lb			20 447 kg	45,086 lb
Differential Steering	18 622 kg	41,062 lb	19 009 kg	41,914 lb	19 904 kg	43,888 lb	20 747 kg	45,747 lb

Bulldozer Specifications

	S STD	S LGP	SU STD	SU XL	SU XW	A STD	A XL	A XW	PAT XL	PAT XW	PAT LGP
Blade Capacity	3.89 m ³ 5.09 yd ³	3.70 m ³ 4.83 yd ³	5.61 m ³ 7.34 yd ³	5.61 m ³ 7.34 yd ³	5.62 m ³ 7.35 yd ³	3.18 m ³ 4.16 yd ³	3.93 m ³ 5.14 yd ³	4.30 m ³ 5.63 yd ³	4.84 m ³ 6.33 yd ³	5.08 m ³ 6.65 yd ³	4.21 m ³ 5.50 yd ³
Width	3360 mm 11.00 ft	3990 mm 13.08 ft	3260 mm 10.66 ft	3260 mm 10.66 ft	3556 mm 11.66 ft	4166 mm 13.66 ft	4165 mm 13.66 ft	4200 mm 13.75 ft	3620 mm 11.91 ft	3794 mm 12.41 ft	4173 mm 13.69 ft
Height	1257 mm 50 in	1101 mm 44 in	1412 mm 56 in	1412 mm 56 in	1412 mm 56 in	1034 mm 41 in	1155 mm 45 in	1169 mm 46 in	1207 mm 48 in	1207 mm 48 in	1228 mm 48 in
Digging Depth	473 mm 19 in	655 mm 26 in	473 mm 19 in	459 mm 18 in	459 mm 18 in	506 mm 20 in	524 mm 21 in	500 mm 20 in	732 mm 29 in	732 mm 29 in	711 mm 28 in
Ground Clearance	1104 mm 44 in	1083 mm 43 in	1104 mm 44 in	1195 mm 47 in	1195 mm 47 in	1142 mm 45 in	1205 mm 47 in	1242 mm 49 in	1181 mm 47 in	1181 mm 47 in	1283 mm 51 in
Maximum Tilt	765 mm 30 in	701 mm 28 in	743 mm 29 in	743 mm 29 in	743 mm 29 in	408 mm 16 in	408 mm 16 in	408 mm 16 in	440 mm 17 in	460 mm 18 in	502 mm 20 in
Weight*	2599 kg 5731 lb	2801 kg 6176 lb	2699 kg 5951 lb	2973 kg 6555 lb	2949 kg 6500 lb	2727 kg 6013 lb	3109 kg 6855 lb	3257 kg 7180 lb	3246 kg 7150 lb	3314 kg 7300 lb	3670 kg 8075 lb
Weight**									1343 kg 2960 lb	1385 kg 3050 lb	1591 kg 3500 lb

Features

- cutting edges are DH-2 steel and end bits are DH-3 steel for maximum durability
- dozer lift cylinders mount to top corners of radiator guard to improve mechanical advantage
- single lever controls all blade movements
- angle dozers available with two tilt cylinders, which replace the two tilt braces

* Includes push arms, blade, blade tilt cylinder(s), cutting edges and miscellaneous hardware components

** PAT blade only

Dimensions

(approximate)

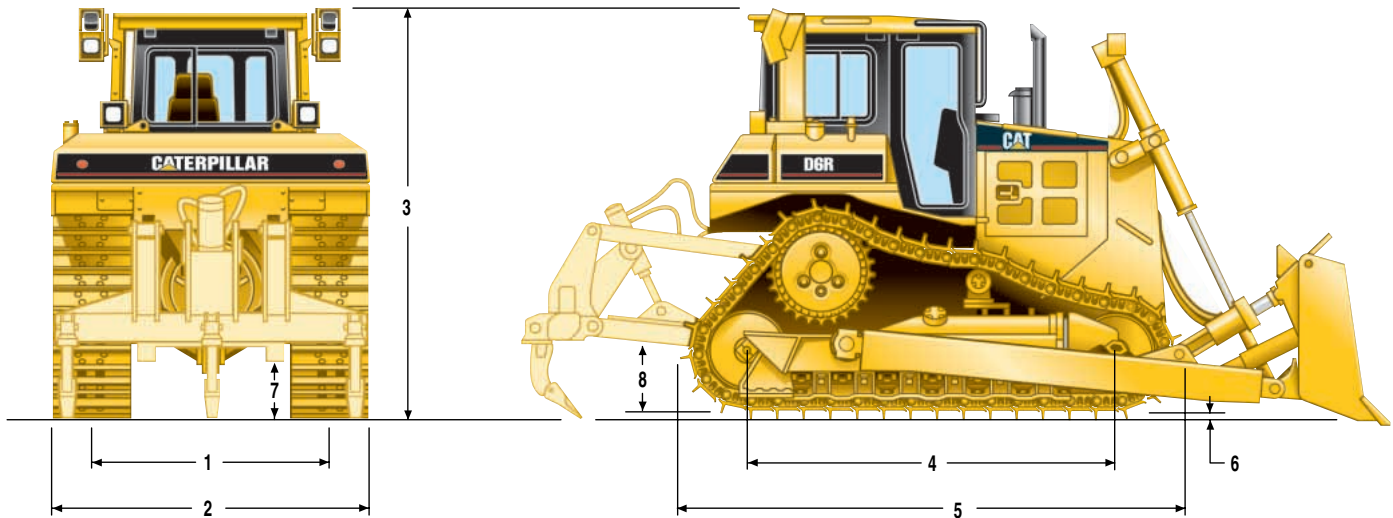

Tractor Dimensions

	STD		XL		XW		LGP	
1 Track gauge	1880 mm	74 in	1880 mm	74 in	2030 mm	80 in	2225 mm	88 in
2 Width of tractor								
Over trunnions	2640 mm	8 ft 8 in	2640 mm	8 ft 8 in	2950 mm	9 ft 8 in	3428 mm	8 ft 8 in
Without trunnions (std. track)	2440 mm	8 ft 0 in	2440 mm	8 ft 0 in	2740 mm	9 ft 0 in	3150 mm	10 ft 4 in
3 Machine height from tip of grouser:								
Stack	3143 mm	10 ft 4 in	3143 mm	10 ft 4 in	3143 mm	10 ft 4 in	3193 mm	10 ft 6 in
ROPS	3195 mm	10 ft 6 in	3195 mm	10 ft 6 in	3195 mm	10 ft 6 in	3245 mm	10 ft 8 in
4 Length of track on ground	2610 mm	8 ft 7 in	2821 mm	9 ft 3 in	2821 mm	9 ft 3 in	3243 mm	10 ft 8 in
5 Length of basic tractor	3860 mm	12 ft 8 in	3860 mm	12 ft 8 in	3860 mm	12 ft 8 in	4247 mm	13 ft 11 in
With following attachments add:								
Drawbar	217 mm	8.5 in	217 mm	8.5 in	217 mm	8.5 in	251 mm	9.9 in
Ripper Multi-Shank (tip at ground line)	1403 mm	4 ft 7 in	1403 mm	4 ft 7 in	1403 mm	4 ft 7 in	—	—
Winch	517 mm	1 ft 8 in	517 mm	1 ft 8 in	517 mm	1 ft 8 in	397 mm	1 ft 4 in
S Blade	1043 mm	3 ft 5 in	—	—	—	—	1218 mm	4 ft 0 in
SU Blade	1235 mm	4 ft 1 in	1472 mm	4 ft 10 in	1472 mm	4 ft 10 in	—	—
A Blade	1147 mm	3 ft 9 in	1349 mm	4 ft 5 in	1349 mm	4 ft 5 in	—	—
PAT Blade	—	—	1412 mm	4 ft 8 in	1412 mm	4 ft 8 in	1718 mm	5 ft 8 in
6 Height of grouser	65 mm	2.6 in	65 mm	2.6 in	65 mm	2.6 in	65 mm	2.6 in
7 Ground clearance	383 mm	1 ft 3 in	383 mm	1 ft 3 in	383 mm	1 ft 3 in	433 mm	1 ft 5 in
Track pitch	203 mm	8.0 in	203 mm	8.0 in	203 mm	8.0 in	203 mm	8.0 in
Number of shoes per side	39		41		41		45	
Number of rollers per side	6		7		7		8	
Standard shoe	560 mm	22 in	560 mm	22 in	760 mm	30 in	915 mm	36 in
Ground contact area (std. track)	2.92 m ²	4531 in ²	3.16 m ²	4897 in ²	4.30 m ²	6664 in ²	5.93 m ²	9199 in ²
Ground pressure	0.627 kg/cm ²	8.92 psi	0.607 kg/cm ²	8.64 psi	0.462 kg/cm ²	6.57 psi	0.349 kg/cm ²	4.96 psi
8 Drawbar height								
From ground face of shoe	511 mm	1 ft 8 in	511 mm	1 ft 8 in	511 mm	1 ft 8 in	561 mm	1 ft 10 in

Standard Equipment

Electrical

- Alternator, 70-amp brushless
- Alarm, backup
- Batteries, two maintenance free 12V (24V system)
- Converter, 12V, 10 amp with 2 power outlets
- Connector, diagnostic
- Connectors, Deutsch
- Horn, forward warning
- Starting receptacle

Operator Environment

- Armrest, adjustable
- Canopy, ROPS/FOPS
- Hour meter, electronic
- Caterpillar Monitoring System
 - with coolant temperature, power train oil, hydraulic oil and fuel gauge, tachometer, odometer, gear indicator and diagnostic functions
- Mirror, rearview
- Pedal, decelerator
- Foot pads, dash
- Seat, vinyl suspension
- Seat belt, retractable 76 mm (3 in.)
- Throttle, electronic

Power Train

- Caterpillar C9 diesel electronic turbocharged and aftercooled engine with flexible fuel system
- Advanced Modular Cooling System (AMOCS)
- Coolant, extended life
- Decelerator
- Fan, blower
- Final drives, three planetary gears
- Fuel priming pump
- Muffler with mitered stack
- Air cleaner, precleaner with stratta tube dust ejector
- Air cleaner service indicator, electric
- Prescreener
- Starting aid, air inlet heater
- Starting aid, ether
- Shifting features, automatic
- Torque divider
- Transmission, powershift (3F/3R)
 - with electronic clutch pressure control
- Water separator

Undercarriage

- Adjuster, hydraulic track
- Guards, end track guiding
- Idlers, lifetime lubricated
- Rollers, lifetime lubricated track
- Carrier rollers (XL, XW and LGP models)
- Heavy Duty Track with moderate service shoes

Other Standard Equipment

- Pilot operated hydraulic controls with control deactivation
- Drains, ecology (engine oil, coolant, hydraulic oil, fuel tank, sediment, power train case)
- Guards, hinged bottom
- Towing device
- Hydraulic, load sensing, two-valve system for bulldozer control
- Radiator doors, louvered, hinged
- S·O·S sampling ports
- Differential Steering or Finger Tip Control with touch shift
- Vandalism protection (eight caplocks)

Optional Equipment (with approximate change in operating weights)

Standard and optional equipment may vary. For specific applications, additional guarding may be required. Consult your Caterpillar Dealer for specifics.

	kg	lb
Bulldozers	(see page 19 for weights)	
Electrical:		
Alternator, 75 AMP	13	29
Alternator, 100 AMP	14	31
Converter, 12V, 20A	1	2
Lights (4)	13	29
Lights (6)	32	71
Lights (8)	33	73
Lights (10)	64	141
Lights (6-Waste)	32	71
Product Link	3	7
Guards:		
Guard, crankcase (HD)	67	148
Guard, crankcase (ES)	130	287
Guard, fuel tank (not for use w/RIP)	102	225
Guard, fuel tank (for use w/RIP)	108	238
Guard, precleaner	11	24
Guard, radiator, bottom (HD)	13	29
Guard, rear (HD)	45	99
Guard, radiator (hinged HD)	38	84
Guard, radiator (hinged HD) punched	19	42
Screen, rear	60	132
Screen, rear (ROPS A/C)	71	157
Striker bars, front	—	—
Striker bars, rear	—	—
Sweeps	356	785
Track Guiding Guards, Moderate Service:		
STD	62	137
XL & XW	51	112
LGP	51	112
Track Roller Guards; Full Length:		
STD	214	472
XL & XW	243	536
LGP	216	476
Operator Environment:		
Air conditioner (ROPS)	277	611
Air conditioner (Hood)	50	110
Armrest, electric adjustable	—	—
Cab	489	1078
Glass, Ultra-Strength 40	51	113
Handles, heavy duty	—	—
Seat, air suspension cloth	1.5	3
Seat, vinyl	—	—
Precleaner with prescreener	—	—
Omission, ROPS Canopy	-391	-862
Power Train:		
Drains, ecology	3	7
Fan, ejector	—	—
Fan, reversible	-9	-20
Grid, radiator core protection	27	60
Fast oil change system	9	20
Cooler, power train oil	—	—

	kg	lb
Undercarriage:		
STD 510 mm (20 in) ES HD	177	390
STD 560 mm (22 in) ES HD	195	430
STD 610 mm (24 in) MS HD	106	234
STD 610 mm (24 in) MS RBT	106	234
XL 510 mm (20 in) ES HD	186	410
XL 560 mm (22 in) ES HD	204	450
XL 610 mm (24 in) MS HD	112	247
XL 610 mm (24 in) MS RBT	112	247
XW 660 mm (26 in) MS HD	-204	-450
XW 710 mm (28 in) MS HD	-186	-410
XW 760 mm (30 in) ES HD	220	485
XW 760 mm (30 in) ES RBT	220	485
LGP 760 mm (30 in) MS/HD	-446	-984
LGP 760 mm (30 in) MS/RBT	-518	-1143
LGP 915 mm (36 in) MS/RBT	—	—
LGP 1000 mm (39 in) self cleaning HD	20	44
Carrier rollers for Standard tractor	156	344
Ripper:		
Ripper, multi-shank	1634	3603
Hydraulics, ripper	46	101
Tooth, curved	74	163
Tooth, 1 straight	-9	-20
Teeth, 2 straight	56	123
Teeth, 3 straight	121	267
Starting Aids:		
Batteries, HD	33	73
Heater, engine coolant	1	2
Winch:		
Winch Arrangement	1156	2549
Installation Arrangement	14	31
Rollers, 3 fairlead	304	670
Rollers, 4 fairlead	325	717
Other Attachments:		
Counterweight	345	760
Counterweight additional	222	490
Drawbar, rigid – long (All)	116	256
Drawbar, rigid – short (STD & XL)	107	236
Enclosure, engine, H.D.	70	154
Sound suppression (STD)	—	—
Sound suppression (XL, XW & LGP)	—	—
Hook, front pull	7	16
Winch control	53	117
Field Installed Attachments:		
Radio/cassette	1	2
Tool kit	5	10

- Waste Handling Arrangements are available from the factory. Contact Custom Products for availability.

ES=Extreme service shoes

MS=Moderate service shoes

HD=Heavy-duty link track

RBT=Rotating bushing track

Notes

D6R Series II Track-Type Tractor

For more complete information on Cat products, dealer services,
and industry solutions, visit us on the web at www.cat.com

© 2005 Caterpillar
Printed in U.S.A.

Materials and specifications are subject to change without notice.
Featured machines in photos may include additional equipment.
See your Caterpillar dealer for available options.

CAT, CATERPILLAR, their respective logos and "Caterpillar Yellow," as well
as corporate and product identity used herein, are trademarks
of Caterpillar and may not be used without permission.

AEHQ5691 (10-05)

CATERPILLAR[®]